

Panoura 18S

3-In-1 Panoramic System

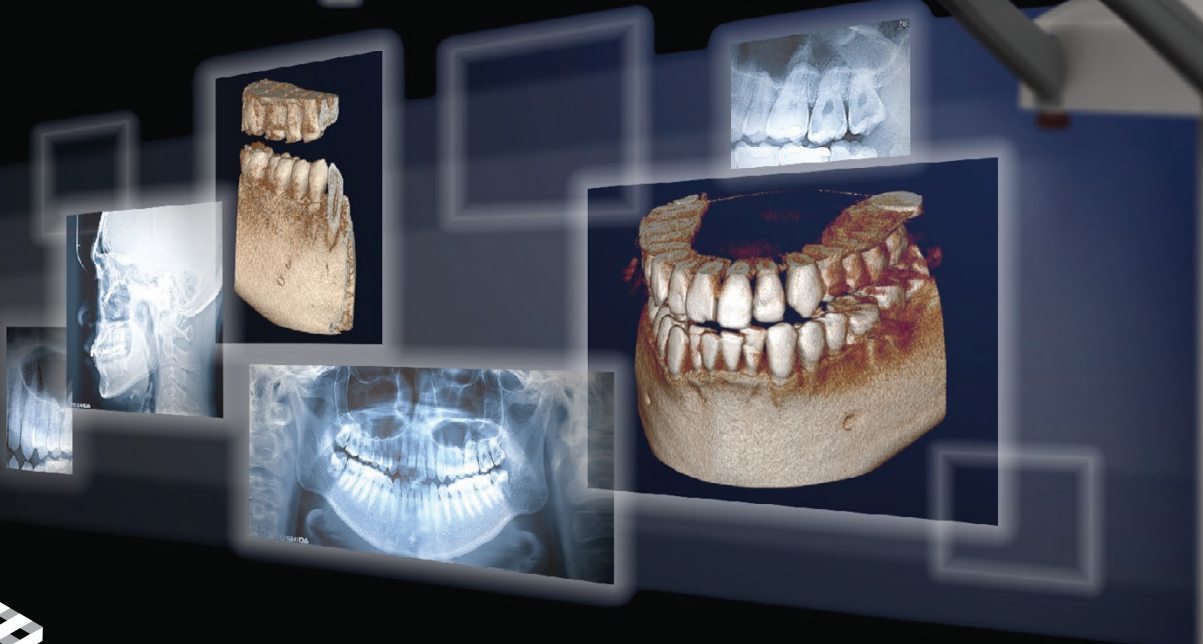
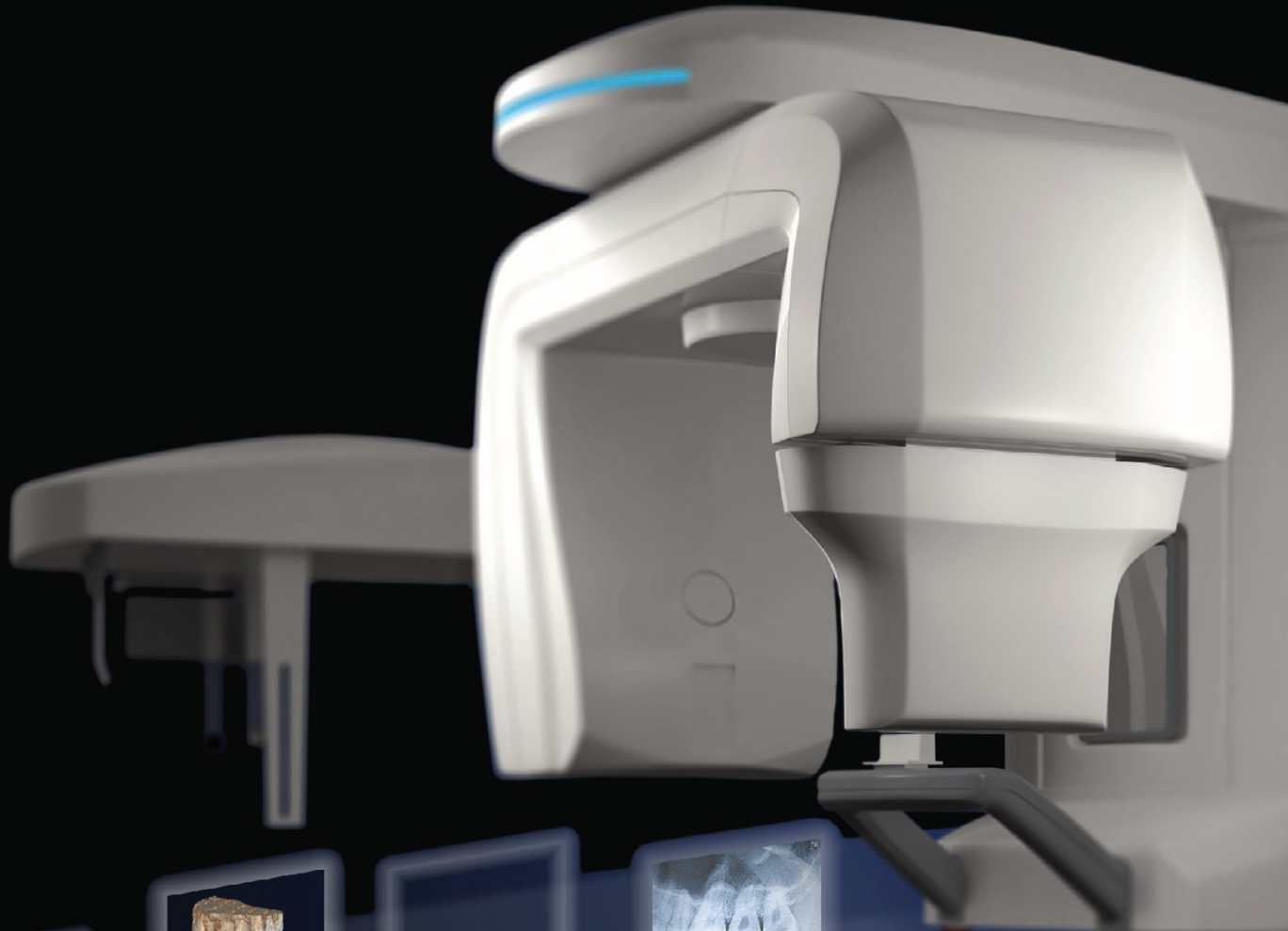

ImageWorks
Generations of Imaging

WWW.ImageWorksCorporation.com/Panoura18S

Two Fields Of View: Dent Mode & Oral Mode

Next Generation 3D Imaging

Confidence built by precision.

Panoura 18S 3D is designed to be an ideal model for 3D panoramic systems. Slim, compact and highly functional.

Adult Pan, Child Pan, Bite Wing, FMX, TMJ, Ceph, 3D imaging for every dental practice.

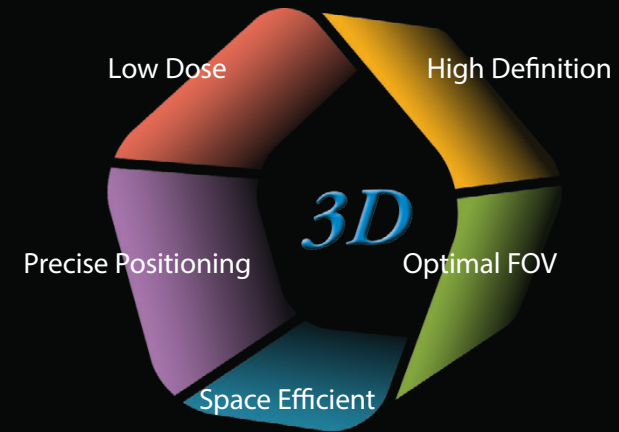

Five benefits essential to an ideal imaging system

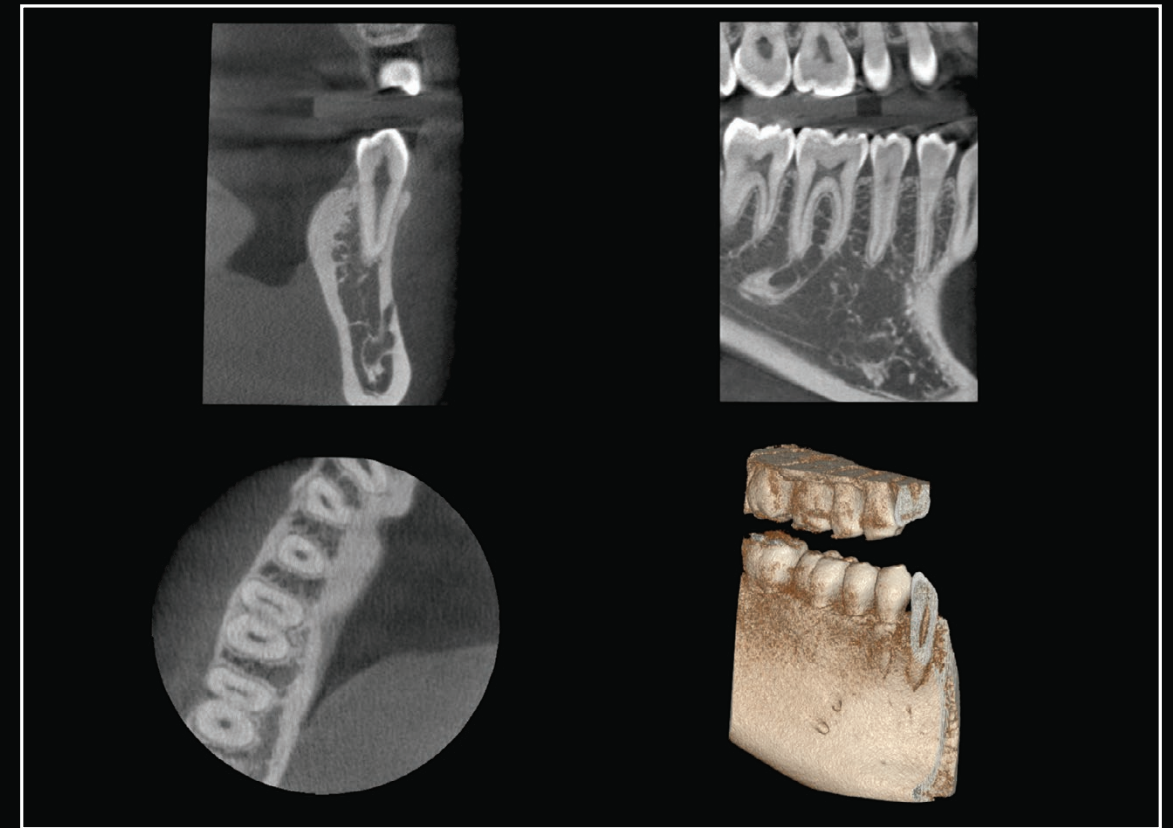

Dent Mode: Half Arch

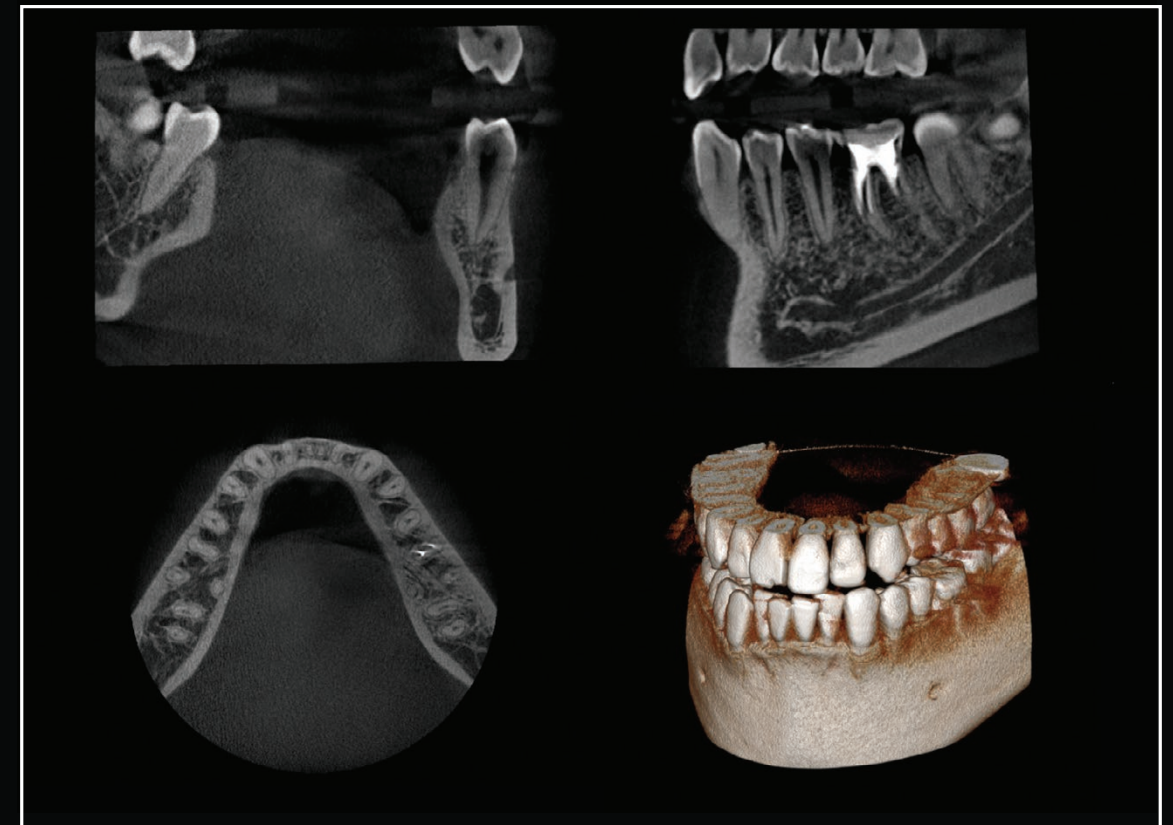

Oral Mode: Full Arch



EVAsoft – Our dental imaging software supplied with the unit, is a powerful image management tool to acquire, process, print and store your images in a simple and effective way. Easy to learn and simple to operate, EVAsoft has all of the advanced features necessary to deliver rapid, effective diagnosis. From the simplicity of tab navigation to the outstanding value it offers, EVAsoft Dental Image Management software is the choice for any practice. EVAsoft interfaces easily with all popular dental imaging software suites.



OnDemand3D - Cybermed's 3D reconstruction software, OnDemand3D, comes included with 3D versions of the Panoura 18S. OnDemand3D is a sophisticated 3D imaging software with many elements. Highlights are implant placements with a full implant library, tour of the root canal, and complete cross sectional and measuring capabilities. OnDemand3D is a software used worldwide that can import DICOM studies and send DICOM studies to referring practices complete with notes.

5 Benefits essential to an ideal 3D Imaging System

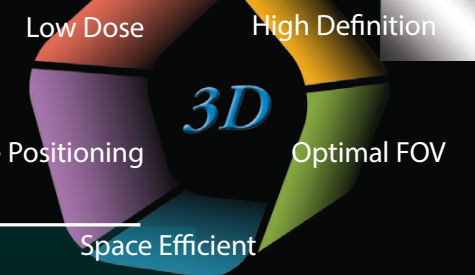

1 80 μm voxels meet precise requirements *High definition*

High definition images comprised of 80μm voxels are so clear they display the precise shape of the root canal and the apical direction. This high level of sharpness can be utilized not only in endodontics, but in a wide array of treatments

Voxel size
80 μm

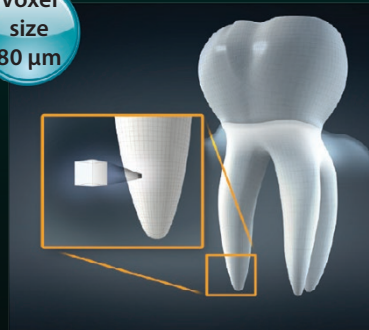

Reference image



3 Bite plate positioning with impression material *Precise patient positioning*

To capture a clear image a bite plate with silicon impression material is added to the head support so a patient's head is held securely in place. The bite plate also ensures an exact replica for future scans of that patient.

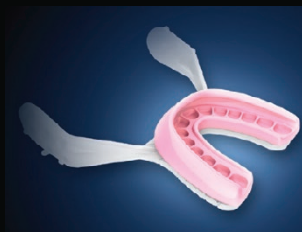
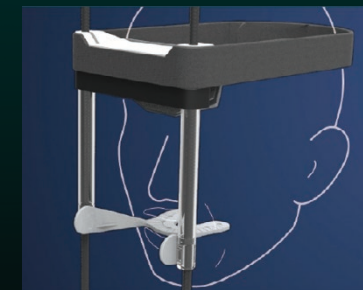

Precise patient positioning every time

In a follow-up treatment, using the same bite plate allows scanning exactly the same area making the observation easier

4 Scanning only the necessary area is accomplished with an FOV smaller than a height of 60mm *Low patient dose*

An FOV with a height of approximately 60mm enables scanning an area large enough to include the opposing teeth while avoiding the lenses of the patients eyes which are highly sensitive to radiation. Panoura 18S 3D protects patients from radiation exposure while capturing the desired area.

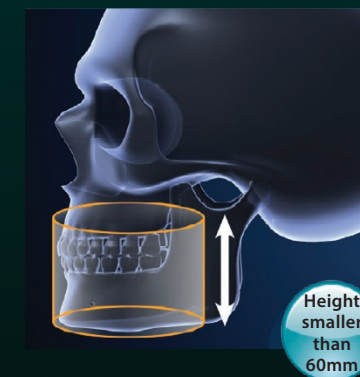

2 Innovative sliding sensor system *Optimal fields of view*

By adopting the sliding sensor system, the correct field of view can be selected from two exposure modes

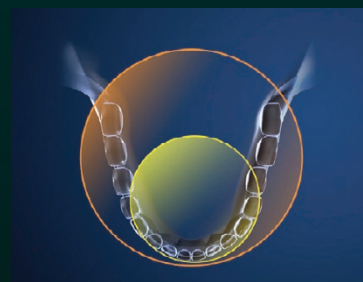

■ Dent Mode

Captures a sharp image in a precise area. Suitable for endodontic and implant treatments

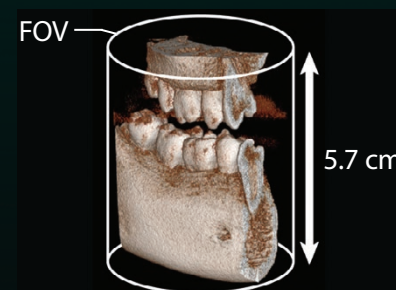

(Dia) 4 cm

■ Oral Mode

Captures the entire maxillary and/or mandibular arch in one shot Suitable for periodontic and multiple tooth implant treatments



(Dia) 7.7 cm

Orbit of sensor at the time of oral mode exposure

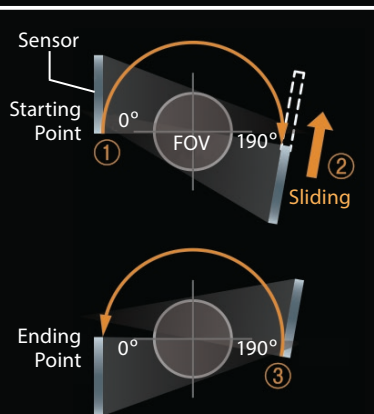

- ① Exposure begins from the starting point, and the rotation arm rotates 190 degrees while scanning.
- ② Sensor slides in the direction of arrow.
- ③ The rotation arm returns to the original position as scanning completes.

Sliding Sensor System

By having the sensor slide, the sensor area is virtually widened so a larger field of view can be obtained. (Patented)

5 Compact body to fit even in the smallest of spaces *Space-efficient design*

As a 3D imaging system with an optional cephalometric arm, the Panoura 18S 3D has a small footprint to fit into tight spaces

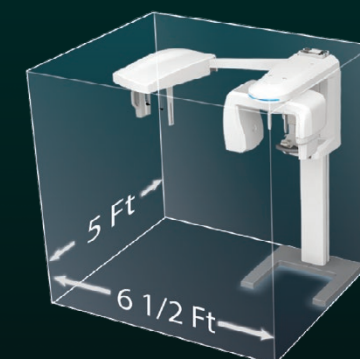

3 Features produce high quality panoramic images

1 Super high definition image quality for a precise diagnosis

- A Cadmium-Telluride CMOS sensor and a unique image construction technology produces sharp images that are free of spinal artifacts.

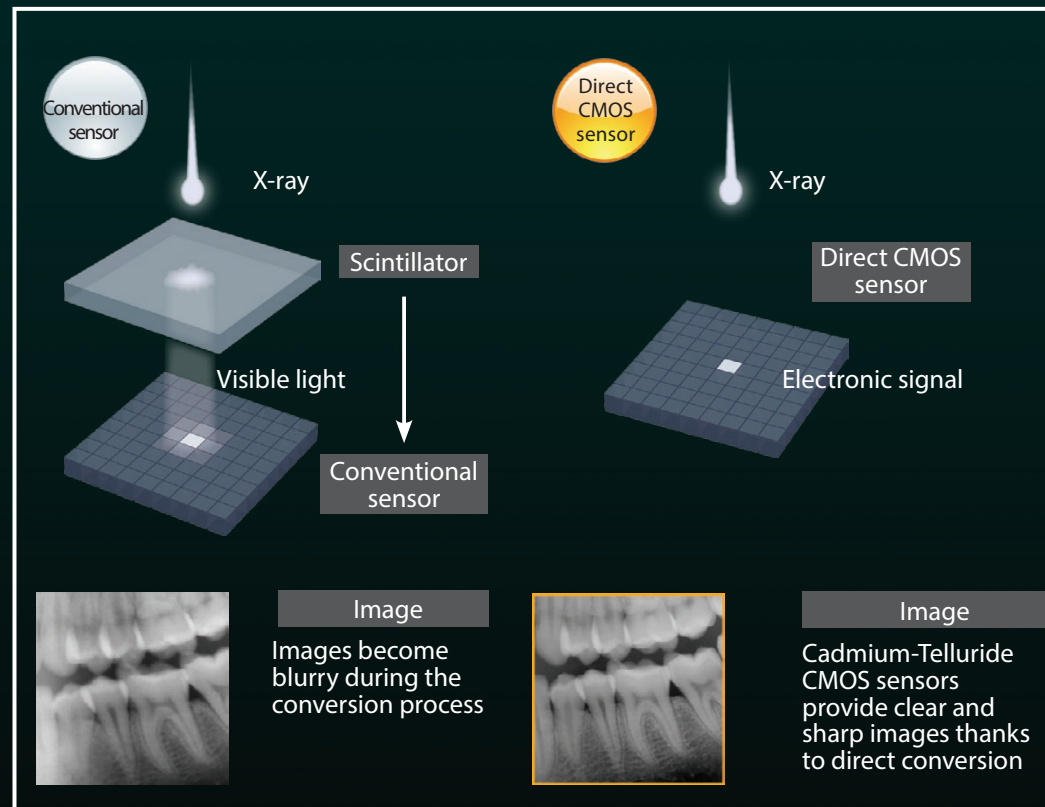

- This process compiles more than 4,500 single high resolution images into one sharp, high-definition panoramic X-ray. (16-bit = 65,536 gray levels)

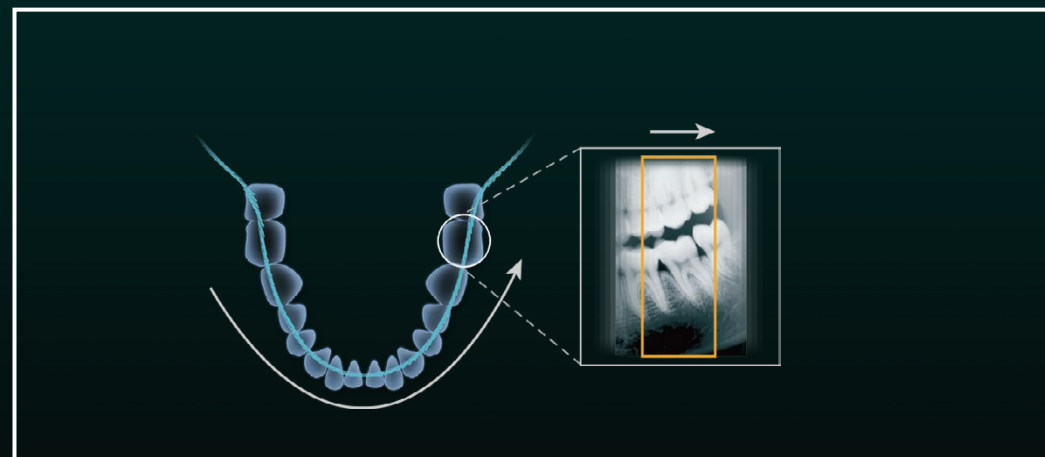

Direct Cadmium-Telluride CMOS sensor

Semiconductor that is used for photon counting directly converts X-rays to electronic signals and creates blur-free images.

Conventional sensor

Conventional sensors convert X-rays to visible light through scintillation, then the CCD element transforms the light into electronic signals. In that process, the scintillator cause the electrons to diffuse, resulting in blurred images.

2 AutoFocus: A multi focal layer technology

- The unique panoramic image construction technology (Image Creator) automatically selects the best focal layer position as the exposure completes. Re-focusing on any spot is also possible after image acquisition is completed.

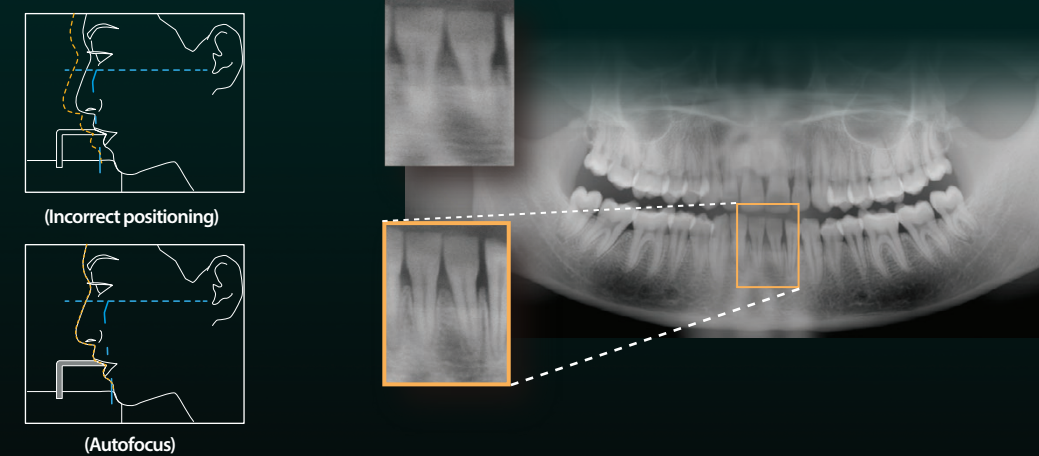
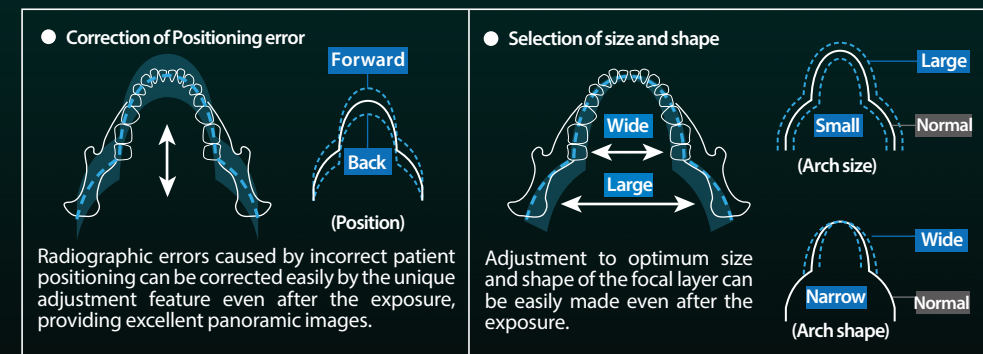

Image Creator

The focal layer position and shape can be adjusted to show the dentition optimally.

- Active tomography allows a reconstruction of the image corresponding to the anatomical shape and size of each patient, even after the exposure.



3 Patient dose reduced by 50%

Direct CMOS sensor enables high quality images while reducing the patient dose by up to 50%. Patient dose is also minimized by shorter exposure times, reducing the risk of retakes caused by patient movement.

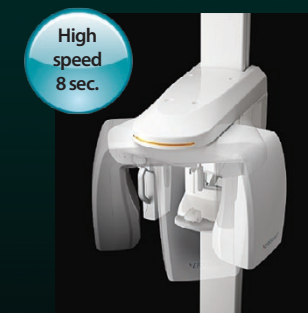

Next generation premium high definition

Premium high-definition
Standard panoramic: 14 seconds

Direct CMOS sensor High definition 14 sec.

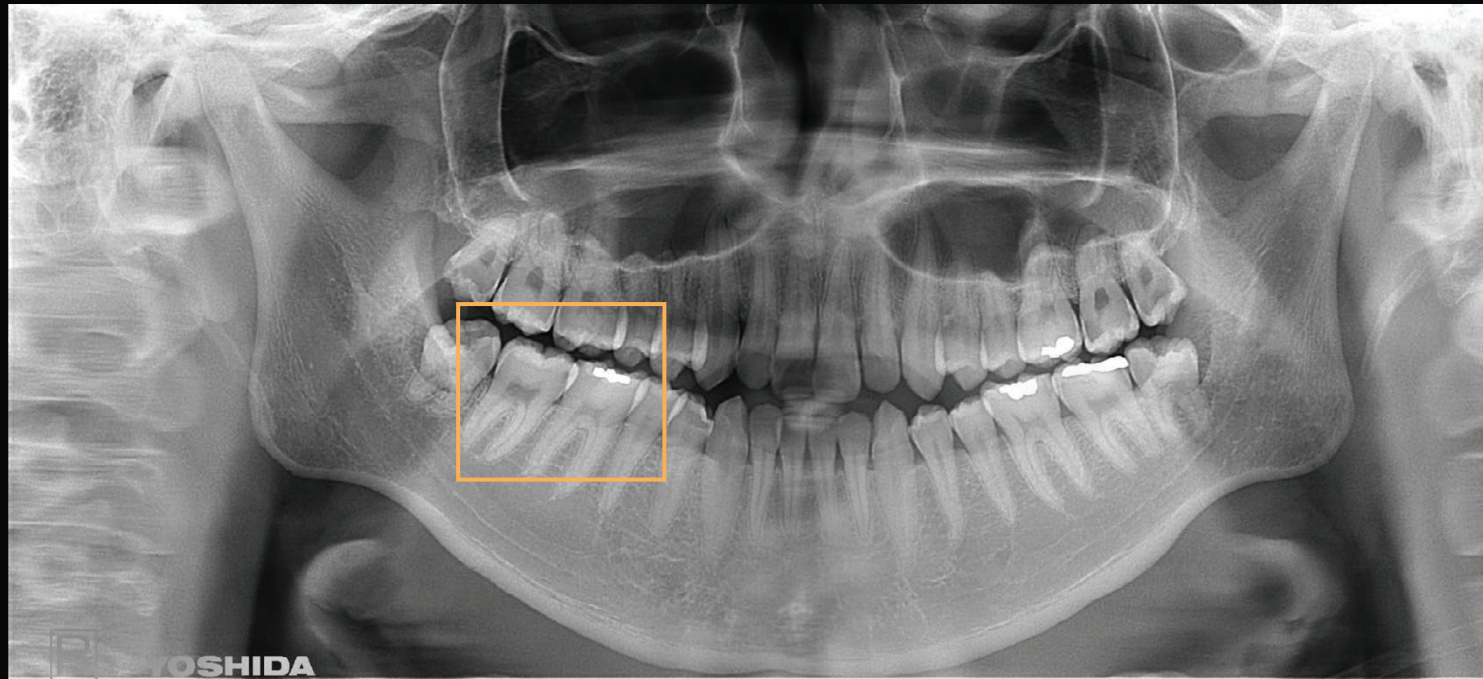

Image comparison

Panoura 18S
Standard panoramic
Direct CMOS sensor High definition 14 sec.

Panoura 18S
High speed exposure mode
Direct CMOS sensor High speed 8 sec.



Conventional sensor image
Conventional sensor 16 sec.

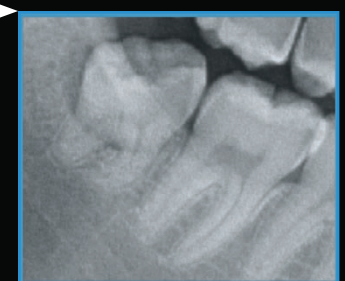

Various exposure times can be selected based upon patient and clinical needs
High speed exposure mode: 8 seconds

Direct CMOS sensor High speed 8 sec.

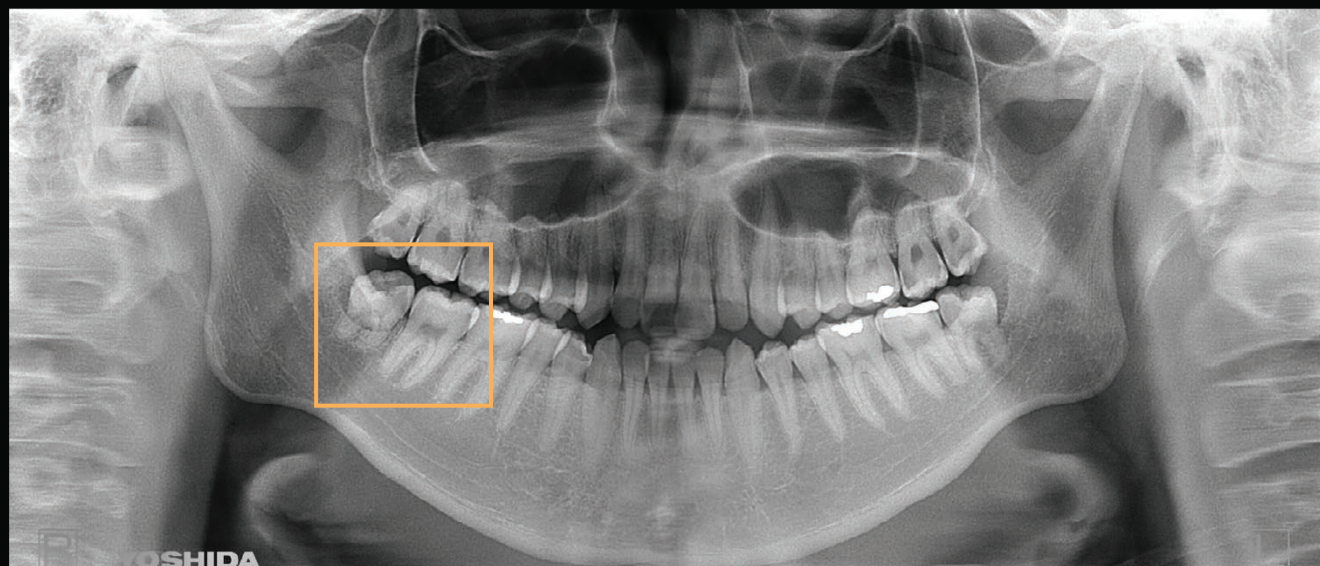

Conventional sensor image

Conventional sensor 16 sec.

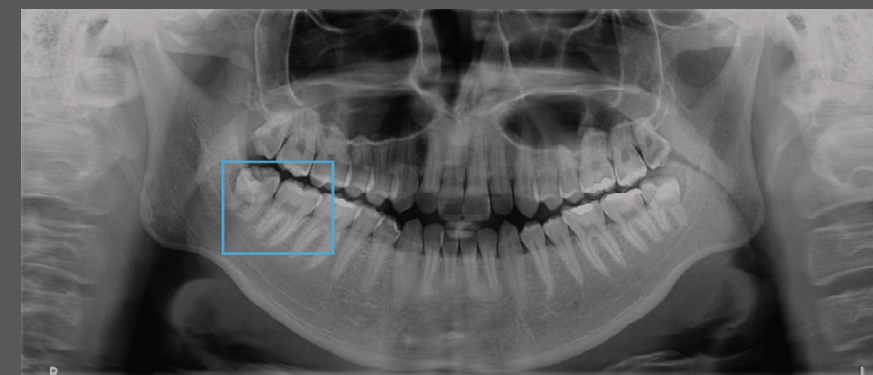

Even an 8 second exposure provides high image quality optimal for accurate clinical diagnosis.

Exposure modes

Panoramic exposure mode



(Standard Panoramic)



(TMJ 2 Views)



(Child Panoramic)

Bitewing and FMX exposure modes are also included.

3D exposure mode



(Dent Mode)



(Oral Mode)

Cephalometric exposure mode

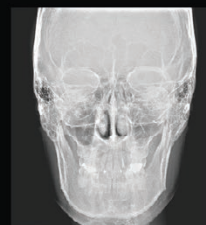

(PA View)



(Lateral View)



(Carpus View)

Easy upgrade to 3D & Cephalometric

With the same simple operability and compact body, it can be easily upgraded to 3D and/or cephalometric as needed.

*Sensor corresponding to 3D cephalometric is needed.

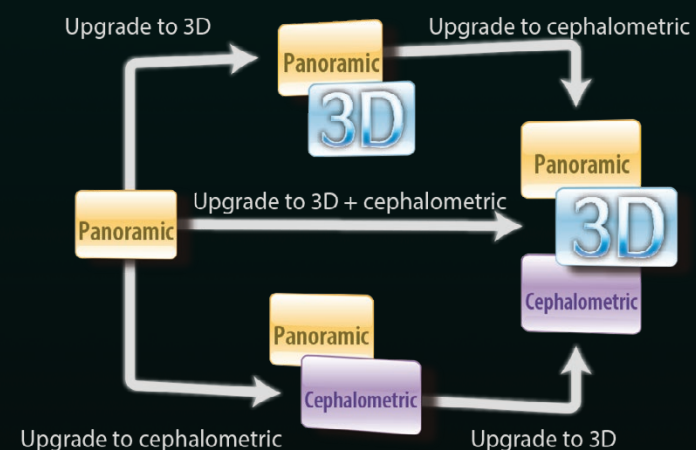

3-point head support

Patient's head is supported at 3 positions to keep it in place during exposure.



Simple positioning

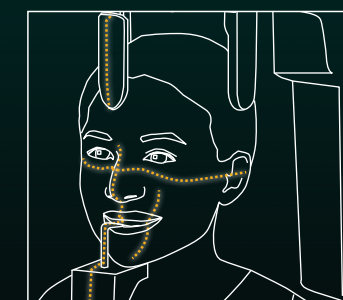

Elevation range of 800mm

The chinrest height is adjustable in an 800mm range to adapt to all patient types, from child to adult, to a patient in a wheelchair.

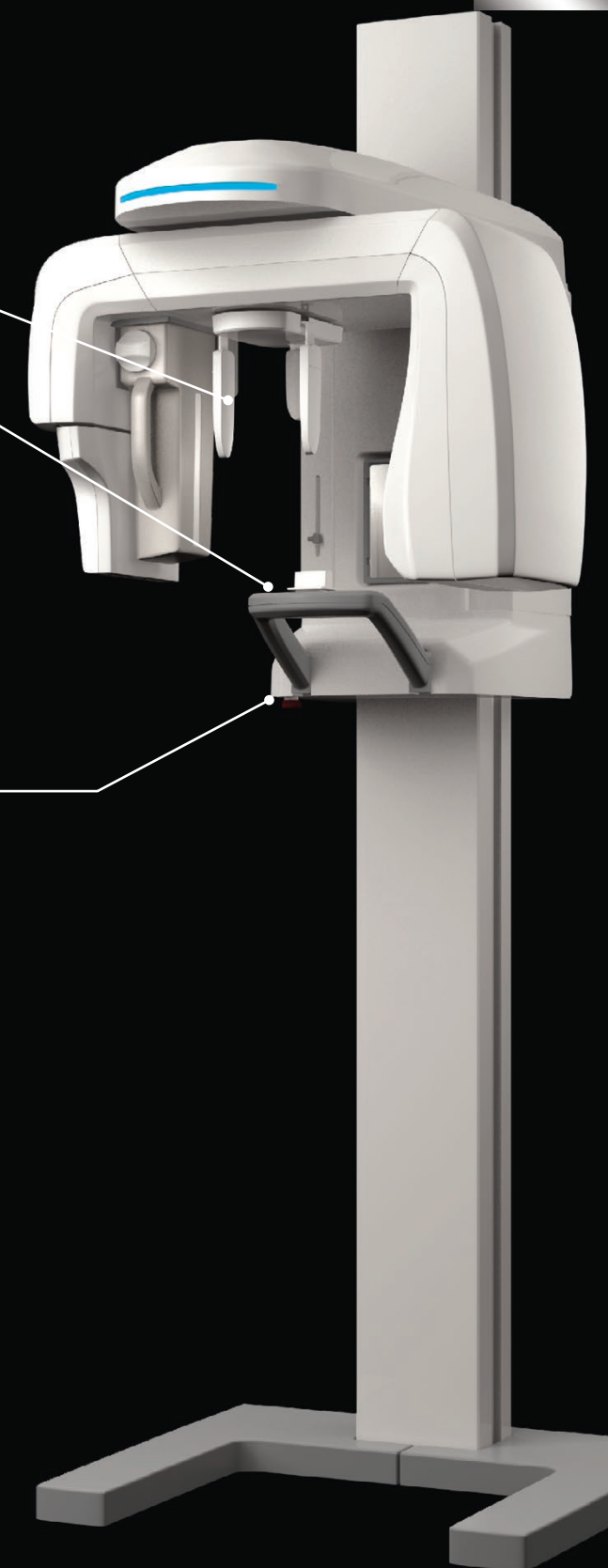

Panoura 18S System Specifications

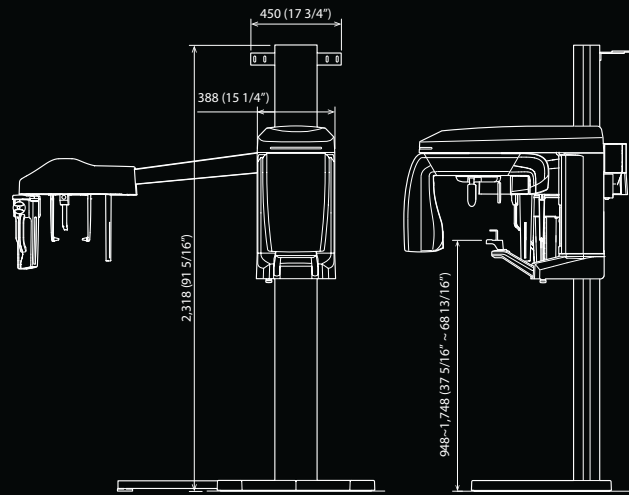
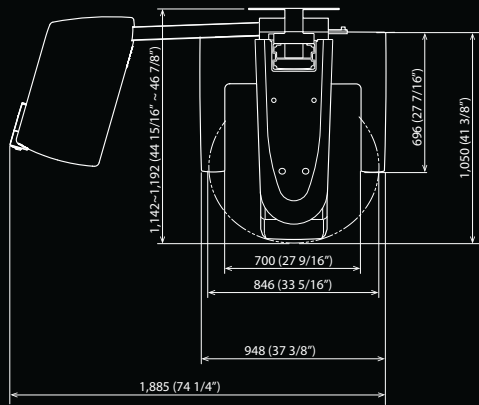

These dimensions include the wide base, long type (tall) and cephalometric attachment. Units = mm (inches)
Clearances have been rounded up to nearest 1/16"
Ranges have been rounded down to nearest 1/16"

Technical Specifications:

Sensor:	Cadmium Telluride direct CMOS	Tube Voltage:	58 - 82 kVp
Levels of Gray:	16-bit (65,536 or 64K)	Tube Current:	2 - 10 mA
Exposure Times (Sec):	8, 14, 16 (Panoramic Adult)	Power Supply:	120 VAC +/- 10% (20A)
	6, 11, 13 (Panoramic Child)	Input:	2 kVa
	4 x 2 (TMJ)	Total Filtration:	2.5mm Aluminum
	8, 10 (Cephalometric)	Software Apps:	EVAsoft (Pan/Ceph)
	11.5 (3D Dent Mode)		OnDemand3D (3D Modes)
	11.5 x 2 (3D Oral Mode)	Weight:	(Pan wall mounted) 287 lbs
Magnification:	1.2 - 1.29 (Panoramic, TMJ)		(Pan/3D wall mounted) 309 lbs
Pixel/Voxel Size:	100 µm square pixel (2D Modes)		(Pan/Ceph wall mounted) 375 lbs
	80 µm cubic voxel (3D Dent Mode)		(Pan/Ceph/3D wall mounted) 397 lbs
	100 µm cubic voxel (3D Oral Mode)		(Pan floor stand) 342 lbs
3D F.O.V.:	4cm x 5.7cm (3D Dent Mode)		(Pan/3D floor stand) 364 lbs
	7.7cm x 5.4 cm (3D Oral Mode)		(Pan/Ceph floor stand) 430 lbs
Focal Spot:	0.5mm x 0.5mm		(Pan/Ceph/3D floor stand) 452 lbs



For Pricing Please Contact Randy Ahlquist 303-888-5500

ImageWorks
250 Clearbrook Road, Suite 240
Elmsford, NY 10523 USA

800.592.6666
P 914.592.6100
F 914.592.6148

www.ImageWorksCorporation.com

Total Imaging Solutions | Veterinary | Dental | Medical

